

FRONT ELEVATION

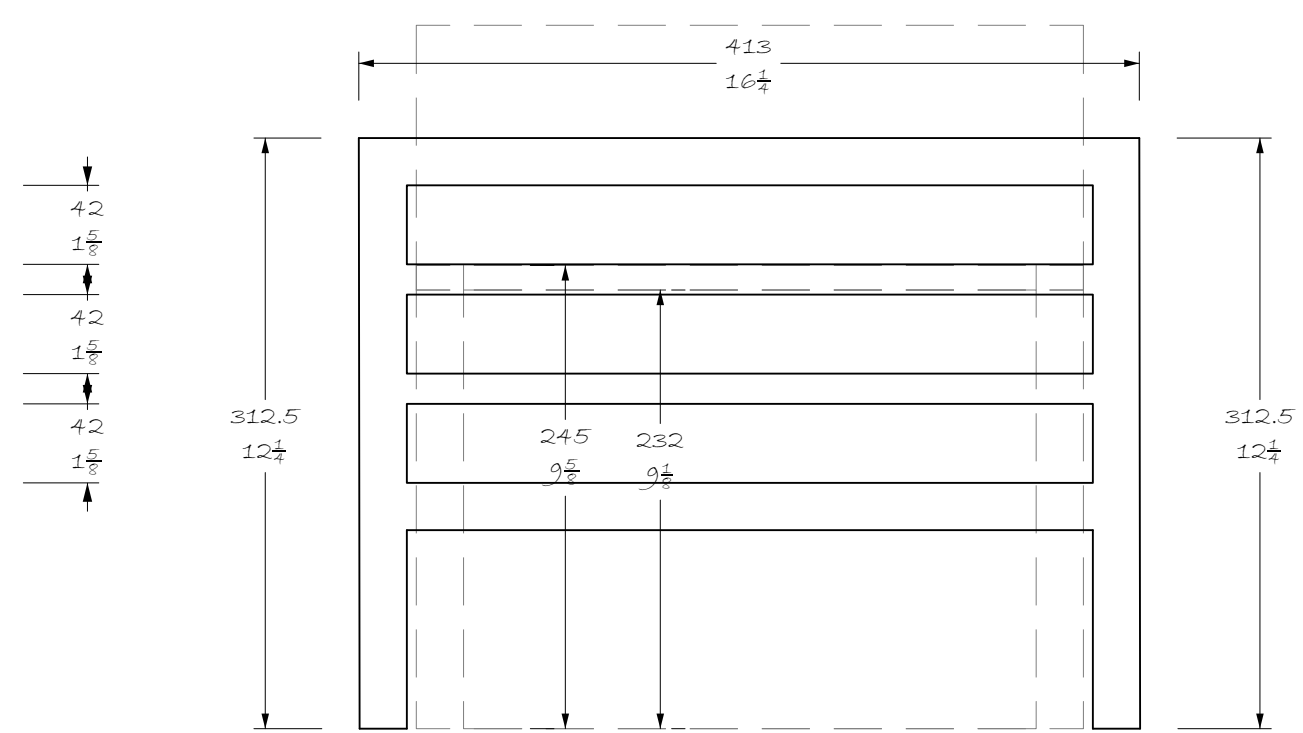

SIDE ELEVATION

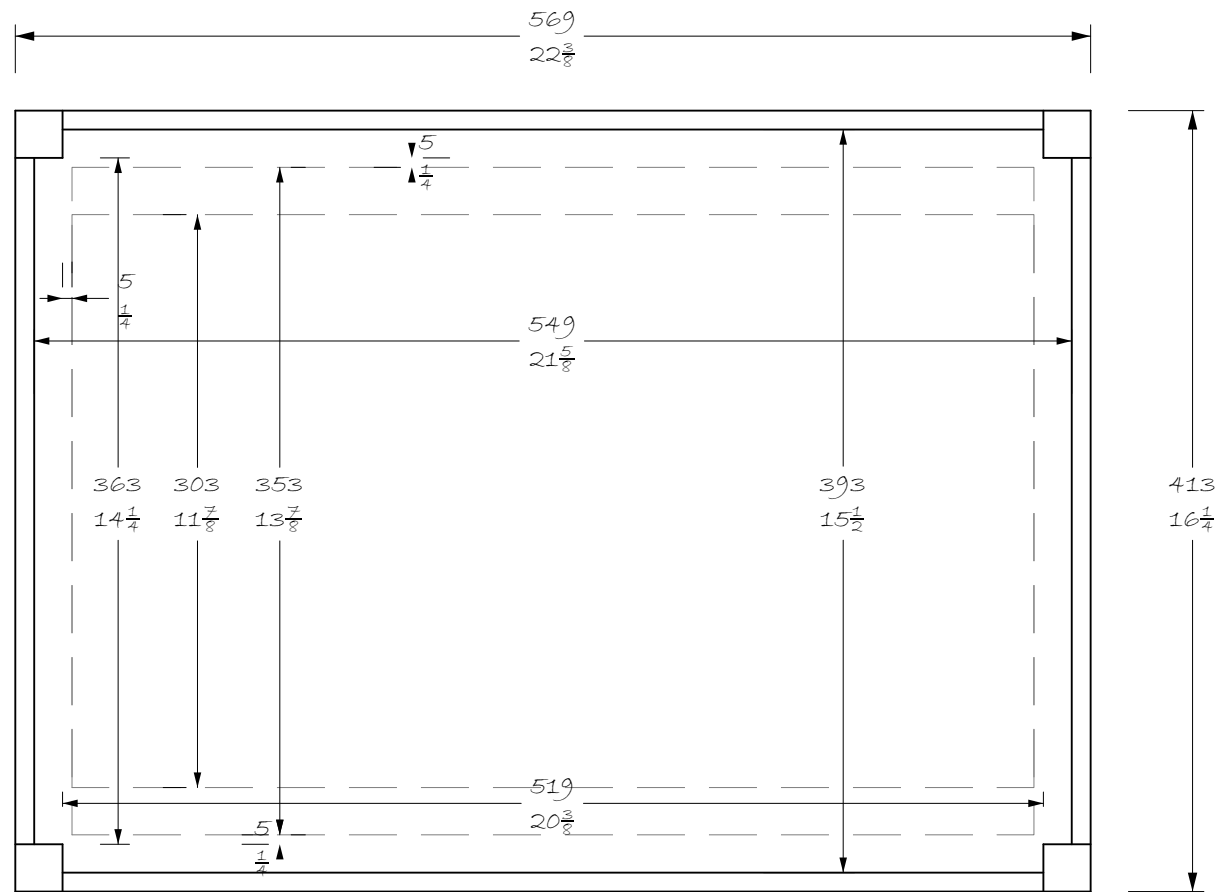

PLAN

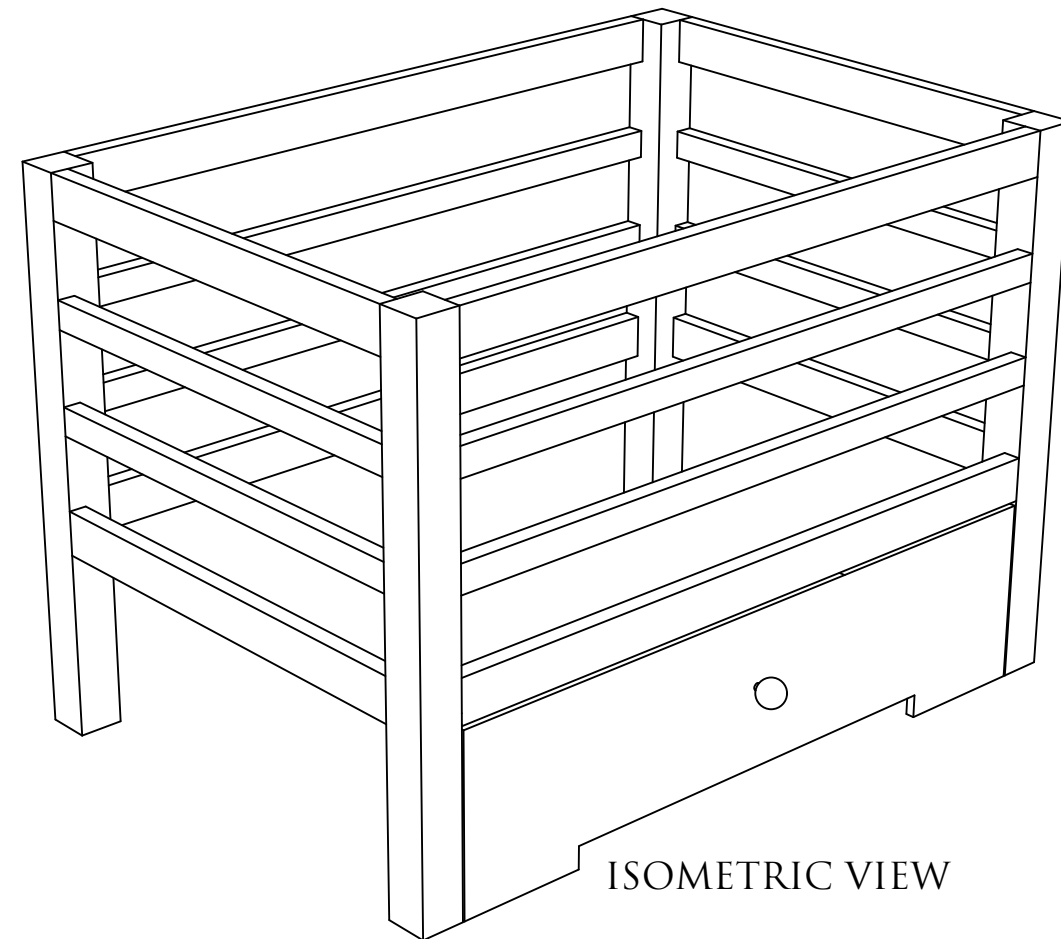

ISOMETRIC VIEW

CLIENT:

CDM Regulations - Design Risk Assessment

The size and shape of individual stones for this project have been designed to satisfy the overall design requirements for the building, bill of quantities or specific project specification.

All persons handling and installing such stones should be aware that there are risks associated with this type of work, which cannot be designed out.

Limestones & Marble are a natural material and may vary in texture, color and veining intensity.

Please consider a dimensional tolerance of +/-5mm or 1/8"

Important: All modular stone/marble fireplace's primary fix must be on a structural brick or block wall using a suitable high bond adhesive. In all instances, these must also be securely mechanically fixed.

© CHESNEYS 2022

CHESNEYS

HEAD OFFICE:
194-196 BATTERSEA PARK ROAD, BATTERSEA, LONDON
TELEPHONE: +44 (0) 20 7627 1410

WEB SITE: WWW.CHESENEYS.CO.UK
E MAIL: SALES@CHESNEYS.CO.UK

SURROUND:

HASTINGS

COMMENTS:

DRAWN BY:

JC

DATE:

SCALE:

1:4 @ A3

INVOICE NUMBER:

DRAWING NO.:

REV: